

Varenummer: 2303039311
Beskrivelse: E+G Fast Spændegreb
MF.100 B-M12

Mål

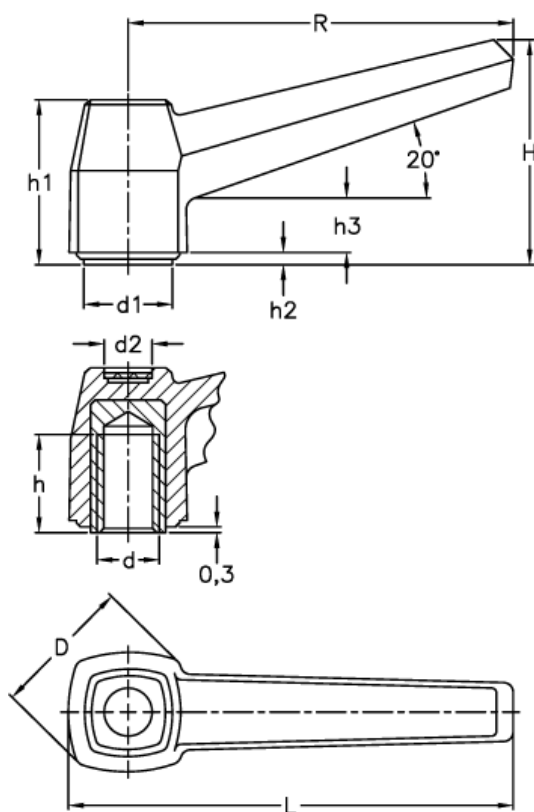

D	= 35	h3	= 16
d1	= 23.5	L	= 115
d2	= 13	R	= 100
d 6H	= M12		
h	= 20		
H	= 57		
h1	= 40		
h2	= 2.4		